

Main supply AHU  
230V 50 Hz  
10 A Fusing

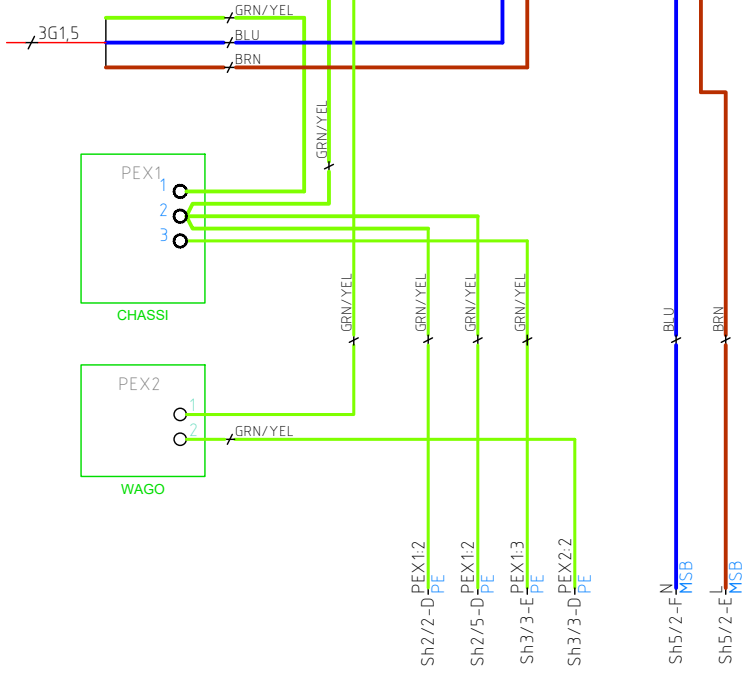

HERU 70T / K  
Circuit diagram - Power  
Power

ART. NUMBER 4040230	DRAWING NUMBER C-0016533	
STATUS	APPR BY KRDO	DRAWN BY FROS
DATE 22.08.2025	REV 0	SHEET 1 / 10

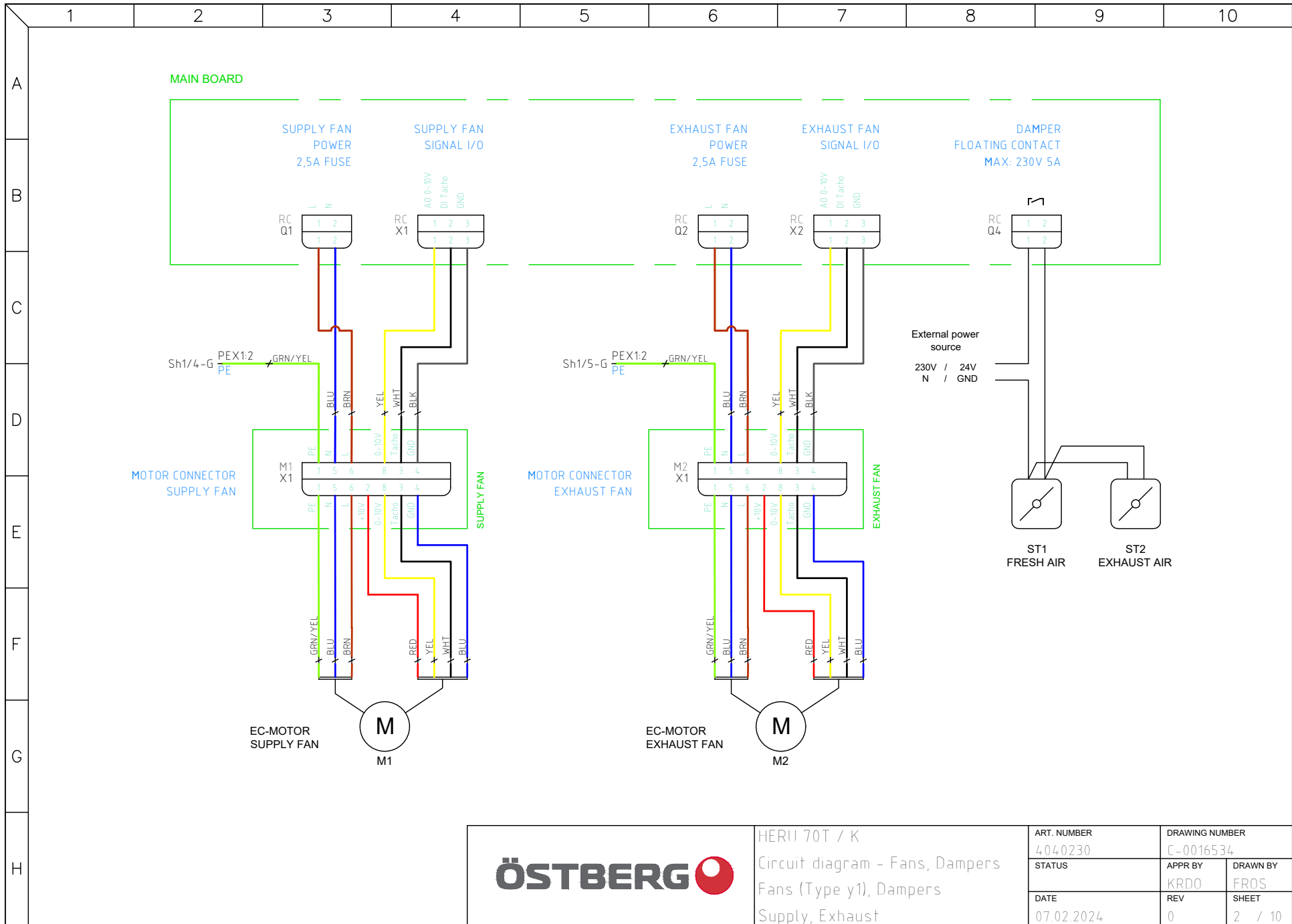

HERU 70T / K  
 Circuit diagram - Fans, Dampers  
 Fans (Type y1), Dampers  
 Supply, Exhaust

ART. NUMBER 4040230	DRAWING NUMBER C-0016534	
STATUS	APPR BY KRDO	DRAWN BY FROS
DATE 07.02.2024	REV 0	SHEET 2 / 10

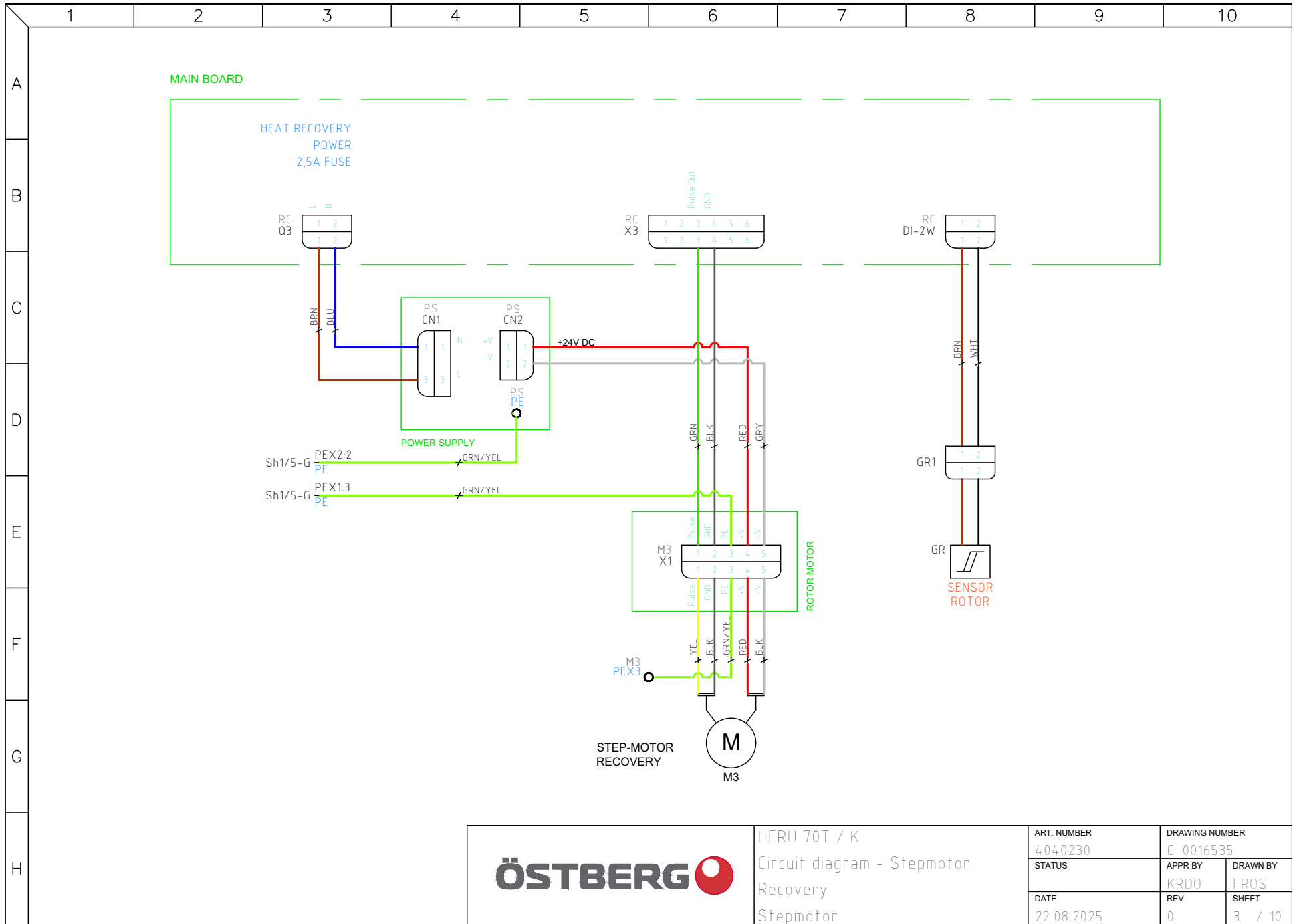

HERU 70T / K  
 Circuit diagram - Stepmotor  
 Recovery  
 Stepmotor

ART. NUMBER 4040230	DRAWING NUMBER C-0016535	
STATUS	APPR BY KRDO	DRAWN BY FROS
DATE 22.08.2025	REV 0	SHEET 3 / 10

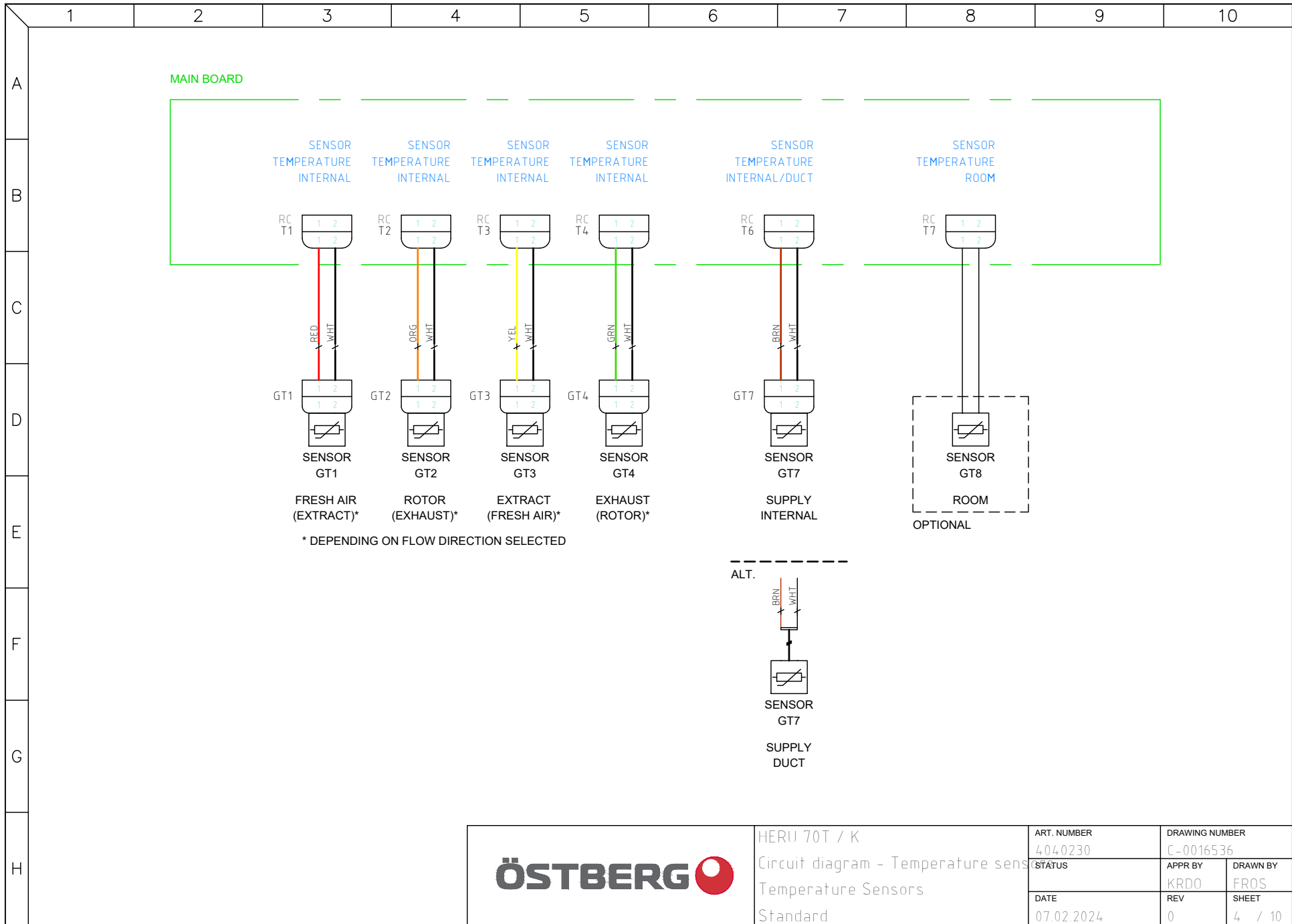

	HERU 70T / K	ART. NUMBER 4040230	DRAWING NUMBER C-0016536	
	Circuit diagram - Temperature sensors	STATUS	APPR BY KRDO	DRAWN BY FROS
	Temperature Sensors	DATE 07.02.2024	REV 0	SHEET 4 / 10
	Standard			

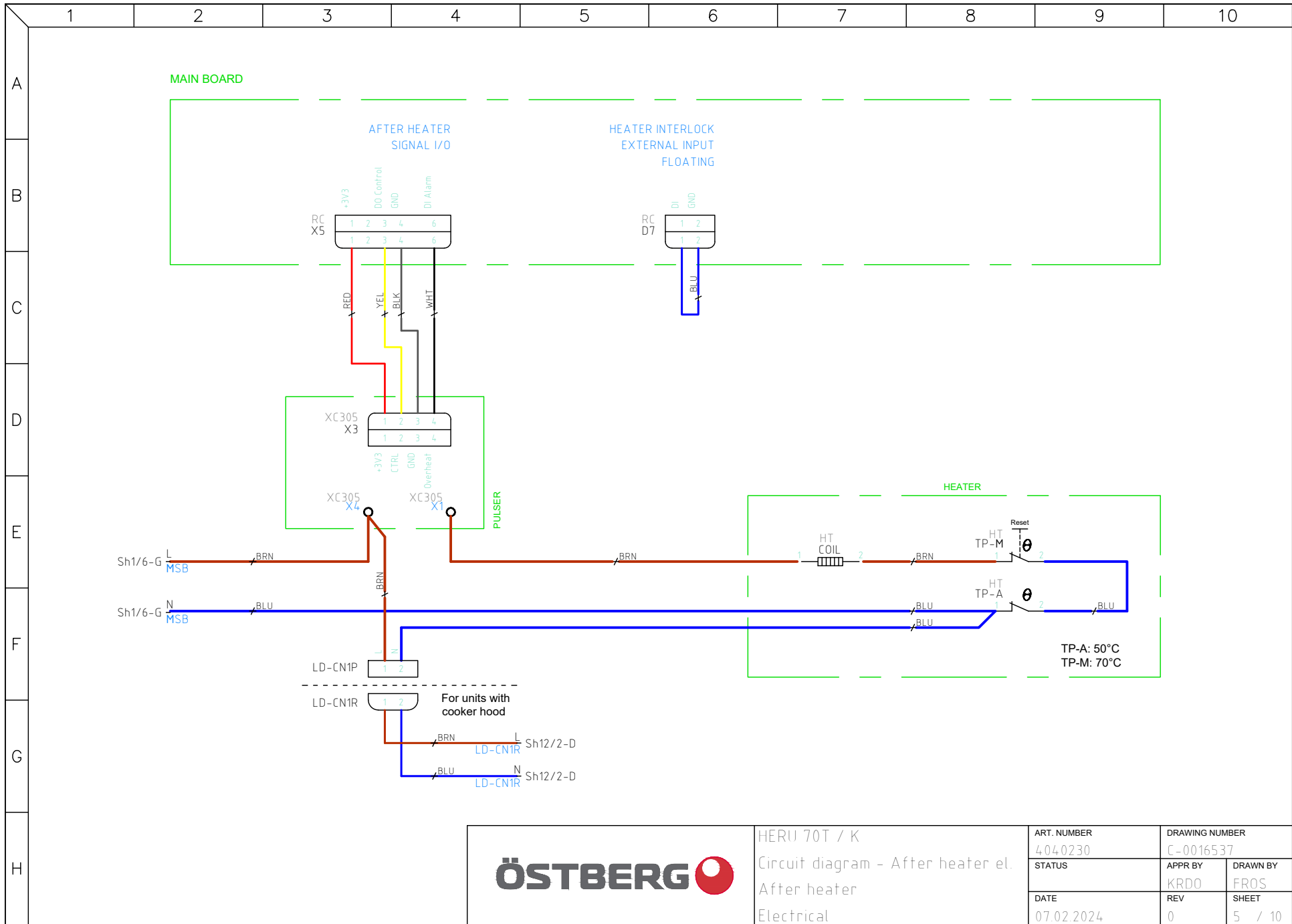

HERU 70T / K  
 Circuit diagram - After heater el.  
 After heater  
 Electrical

ART. NUMBER 4040230	DRAWING NUMBER C-0016537	
STATUS	APPR BY KRDO	DRAWN BY FROS
DATE 07.02.2024	REV 0	SHEET 5 / 10

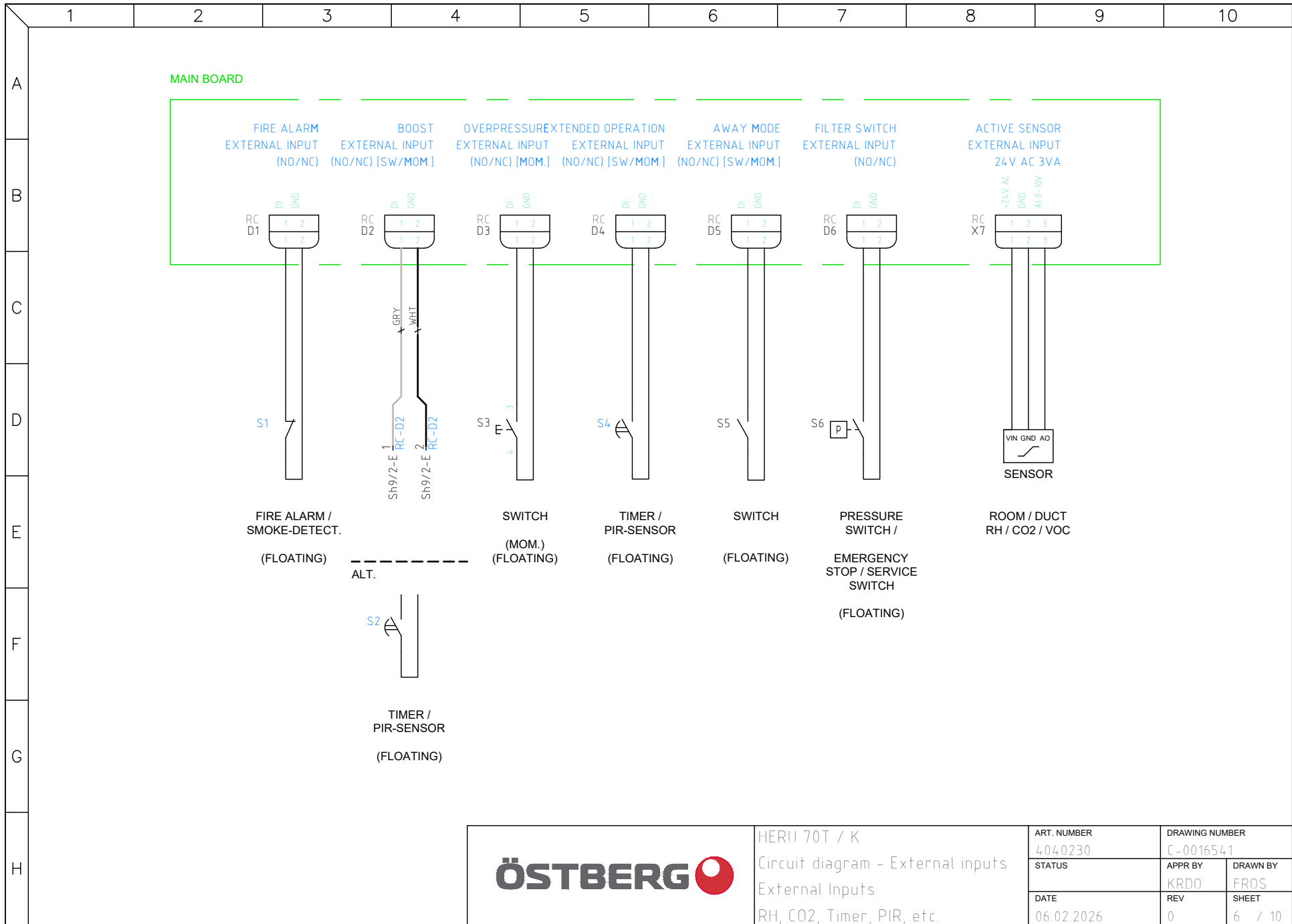

HERU 70T / K  
 Circuit diagram - External inputs  
 External Inputs  
 RH, CO2, Timer, PIR, etc.

ART. NUMBER 4040230	DRAWING NUMBER C-0016541	
STATUS	APPR BY KRDO	DRAWN BY FROS
DATE 06.02.2026	REV 0	SHEET 6 / 10

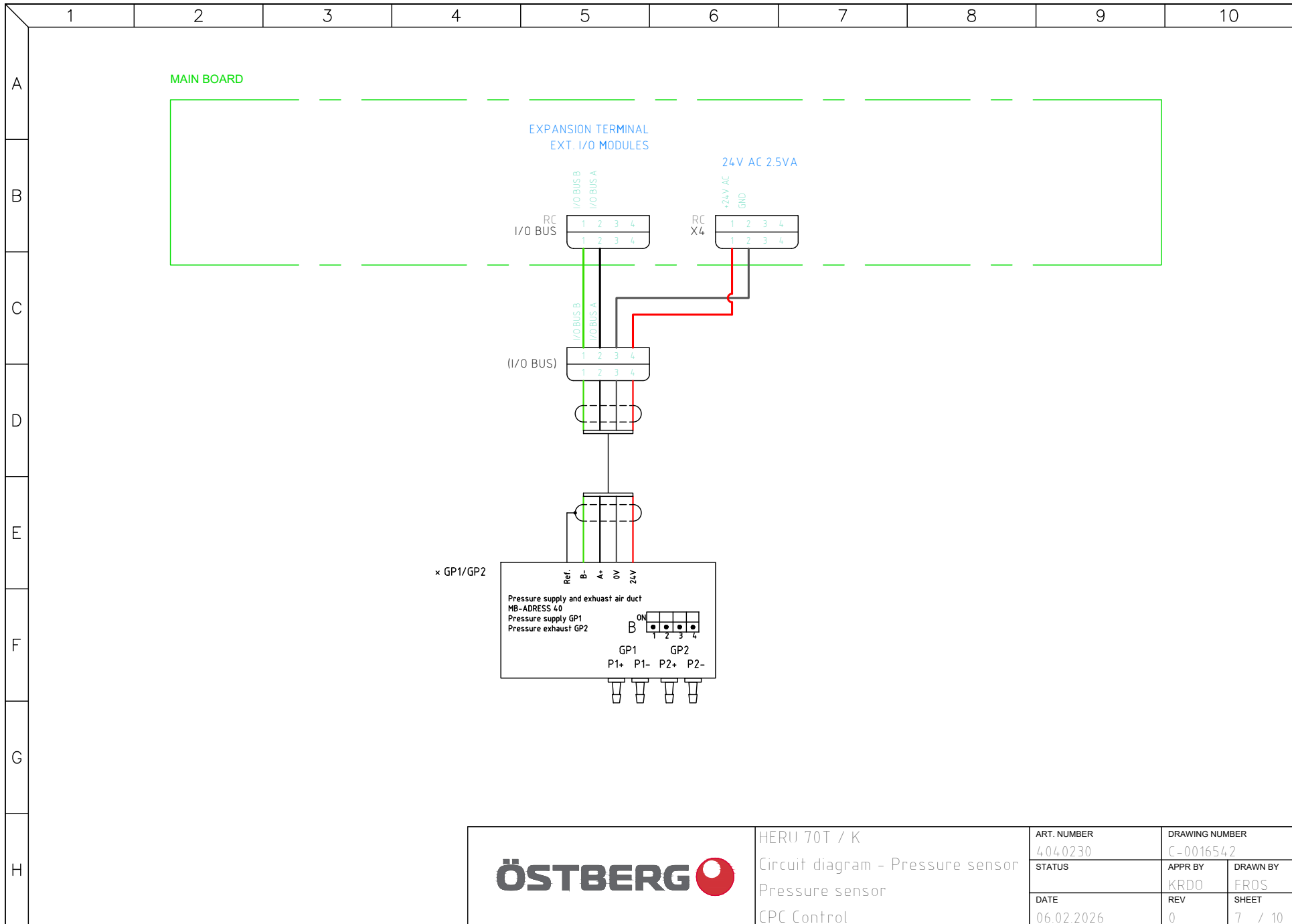

HERU 70T / K  
 Circuit diagram - Pressure sensor  
 Pressure sensor  
 CPC Control

ART. NUMBER 4040230	DRAWING NUMBER C-0016542	
STATUS	APPR BY KRDO	DRAWN BY FROS
DATE 06.02.2026	REV 0	SHEET 7 / 10

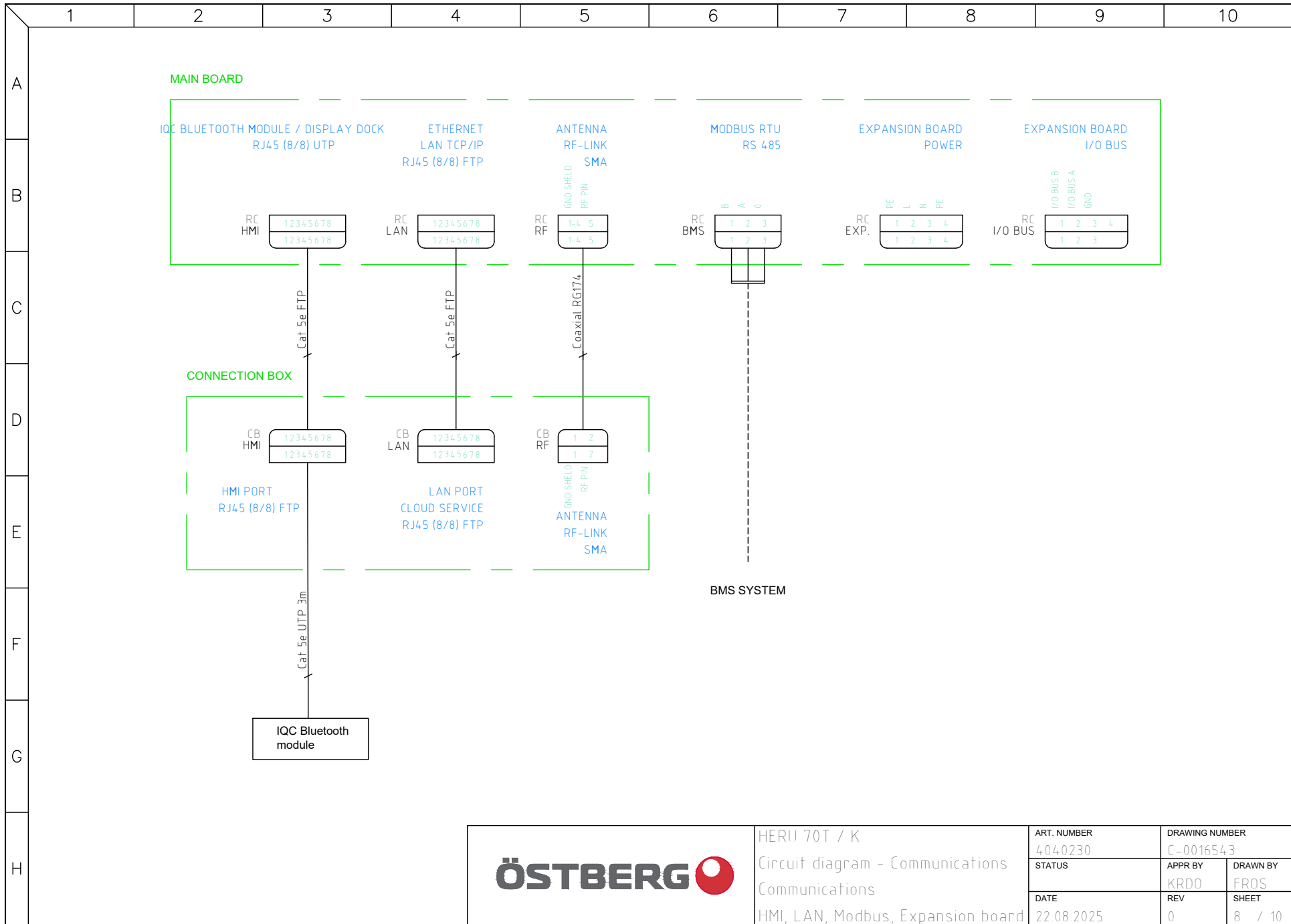

HERU 70T / K  
 Circuit diagram - Communications  
 Communications  
 HMI, LAN, Modbus, Expansion board

ART. NUMBER 4040230	DRAWING NUMBER C-0016543	
STATUS	APPR BY KRDO	DRAWN BY FROS
DATE 22.08.2025	REV 0	SHEET 8 / 10

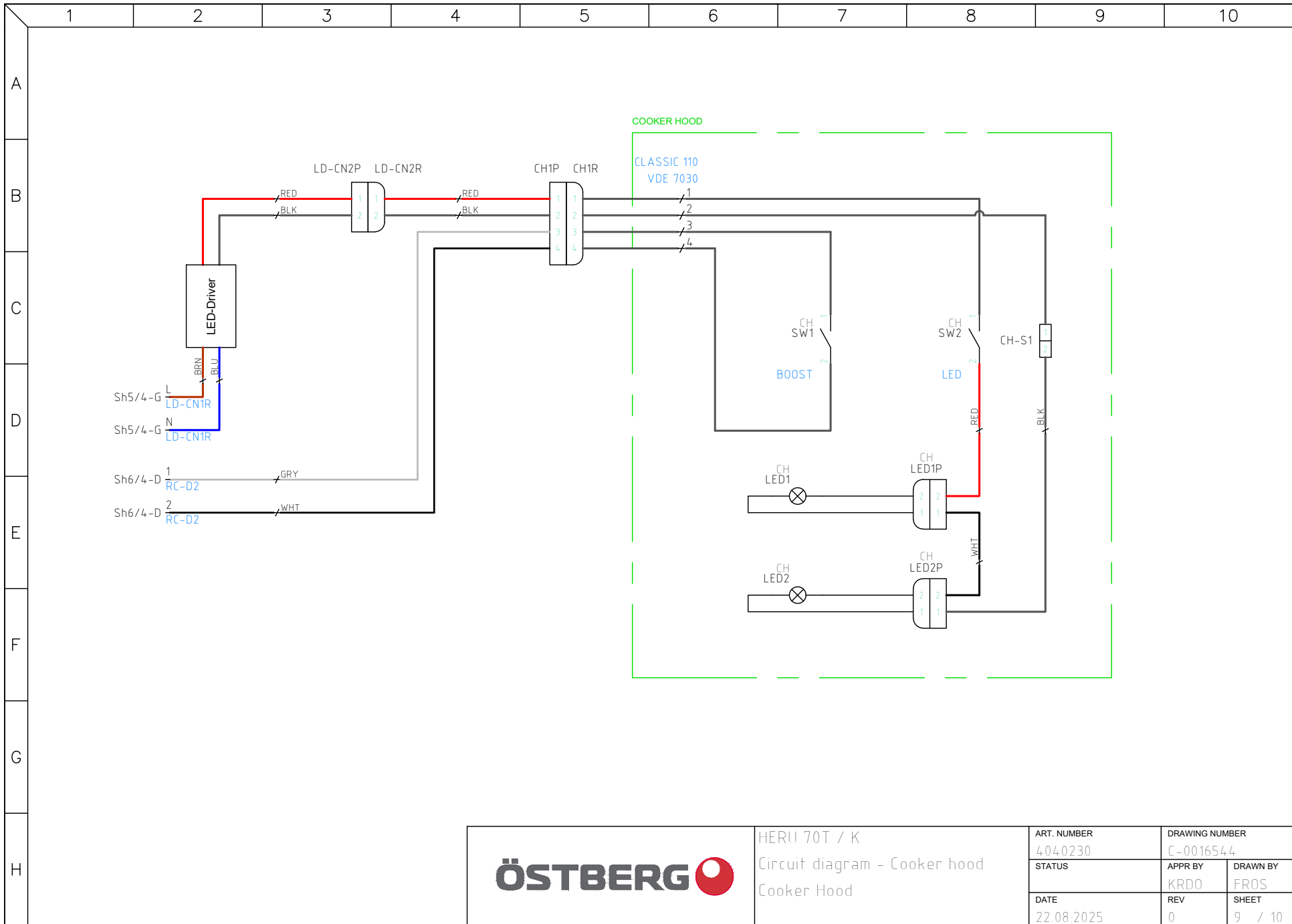

HERU 70T / K  
Circuit diagram - Cooker hood  
Cooker Hood

ART. NUMBER 4040230	DRAWING NUMBER C-0016544	
STATUS	APPR BY KRDO	DRAWN BY FROS
DATE 22.08.2025	REV 0	SHEET 9 / 10

A  
B  
C  
D  
E  
F  
G  
H

SH1	IECCMP1	PIN1	WLAY1	SH2	IECCMP2	PIN2
1	MAIN	N	RQ 1.5mm2-BLU	1	RC-MSa	1
1	MAIN	L	RQ 1.5mm2-BRN	1	RC-MSa	2
1	MAIN	PE	RQ 1.5mm2-GRNYEL	1	PEX1	1
1	RC-MSb	1	RQ 1.5mm2-BLU	5	HT-TP-A	1
1	RC-MSb	2	RQ 1.5mm2-BRN	5	XC305-X4	1
1	RC-PE	1	RQ 1.5mm2-GRNYEL	1	PEX1	2
1	RC-PE	2	UL 1007-AWG 20-GRNYEL	1	PEX2	1
1	PEX1	2	RQ 1.5mm2-GRNYEL	2	M1-X1	1
1	PEX1	2	RQ 1.5mm2-GRNYEL	2	M2-X1	1
1	PEX2	2	UL 1007-AWG 20-GRNYEL	3	PS-PE	1
2	RC-Q1	1	UL 1007-AWG 20-BRN	2	M1-X1	6
2	RC-Q1	2	UL 1007-AWG 20-BLU	2	M1-X1	5
2	RC-X1	1	UL 1007-AWG 22-YEL	2	M1-X1	8
2	RC-X1	2	UL 1007-AWG 22-WHT	2	M1-X1	3
2	RC-X1	3	UL 1007-AWG 22-BLK	2	M1-X1	4
2	RC-Q2	1	UL 1007-AWG 20-BRN	2	M2-X1	6
2	RC-Q2	2	UL 1007-AWG 20-BLU	2	M2-X1	5
2	RC-X2	1	UL 1007-AWG 22-YEL	2	M2-X1	8
2	RC-X2	2	UL 1007-AWG 22-WHT	2	M2-X1	3
2	RC-X2	3	UL 1007-AWG 22-BLK	2	M2-X1	4
3	PS-CN2	1	UL 1007-AWG 20-RED	3	M3-X1	4
3	PS-CN2	2	UL 1007-AWG 20-GRY	3	M3-X1	5
3	RC-DI-2W	1	UL 1007-AWG 22-BRN	3	GR1	1
3	RC-DI-2W	2	UL 1007-AWG 22-WHT	3	GR1	2
3	M3-X1	3	UL 1007-AWG 20-GRNYEL	1	PEX1	3
3	RC-Q3	1	UL 1007-AWG 20-BRN	3	PS-CN1	3
3	RC-Q3	2	UL 1007-AWG 20-BLU	3	PS-CN1	1
3	RC-X3	3	UL 1007-AWG 22-GRN	3	M3-X1	1
3	RC-X3	4	UL 1007-AWG 22-BLK	3	M3-X1	2
4	RC-T1	1	UL 1007-AWG 22-RED	4	GT1	1
4	RC-T1	2	UL 1007-AWG 22-WHT	4	GT1	2
4	RC-T2	1	UL 1007-AWG 22-ORG	4	GT2	1
4	RC-T2	2	UL 1007-AWG 22-WHT	4	GT2	2
4	RC-T3	1	UL 1007-AWG 22-YEL	4	GT3	1
4	RC-T3	2	UL 1007-AWG 22-WHT	4	GT3	2
4	RC-T4	1	UL 1007-AWG 22-GRN	4	GT4	1
4	RC-T4	2	UL 1007-AWG 22-WHT	4	GT4	2
4	RC-T6	1	UL 1007-AWG 22-BRN	4	GT7	1
4	RC-T6	2	UL 1007-AWG 22-WHT	4	GT7	2
5	XC305-X1	1	RQ 1.5mm2-BRN	5	HT-COIL	1
5	HT-COIL	2	RQ 1.5mm2-BRN	5	HT-TP-M	1
5	HT-TP-M	2	RQ 1.5mm2-BLU	5	HT-TP-A	2
5	HT-TP-A	1	RQ 1.5mm2-BLU	5	LD-CN1P	2
5	XC305-X4	1	RQ 1.5mm2-BRN	5	LD-CN1P	1
5	LD-CN1R	1	UL 1569-AWG 18-BRN	9	LED-Driver	-
5	LD-CN1R	2	UL 1569-AWG 18-BLU	9	LED-Driver	-
5	RC-X5	1	UL 1007-AWG 22-RED	5	XC305-X3	1
5	RC-X5	3	UL 1007-AWG 22-YEL	5	XC305-X3	2
5	RC-X5	4	UL 1007-AWG 22-BLK	5	XC305-X3	3
5	RC-X5	6	UL 1007-AWG 22-WHT	5	XC305-X3	4
5	RC-D7	1	RQ 0.75mm2-BLU	5	RC-D7	2
6	RC-D2	1	UL 1007-AWG 22-GRY	9	CH1P	3
6	RC-D2	2	UL 1007-AWG 22-WHT	9	CH1P	4

SH1	IECCMP1	PIN1	WLAY1	PIN2	SH2	IECCMP2	PIN2
8	RC-HMI	-	Cat 5e FTP	-	8	CB-HMI	-
8	CB-HMI	-	Cat 5e UTP	-	8	IOC BT-Module	-
8	RC-LAN	-	Cat 5e FTP	-	8	CB-LAN	-
8	RC-RF	-	Coaxial RG174	-	8	CB-RF	-
9	LED-Driver	-	UL 1569-AWG 20-BLK	-	9	LD-CN2P	2
9	LED-Driver	-	UL 1569-AWG 20-RED	-	9	LD-CN2P	1
9	CH-LED1P	1	UL 1007-AWG 20-WHT	-	9	CH-LED2P	2
9	CH-S1	2	UL 1007-AWG 20-BLK	-	9	CH-LED2P	1
9	CH1R	1	UL 1007-AWG 20-BLK	-	9	CH-SW2	1
9	CH1R	2	UL 1007-AWG 20-BLK	-	9	CH-S1	1
9	CH1R	3	UL 1007-AWG 20-BLK	-	9	CH-SW1	1
9	CH1R	4	UL 1007-AWG 20-BLK	-	9	CH-SW1	2
9	CH-SW2	2	UL 1007-AWG 20-RED	-	9	CH-LED1P	2
9	LD-CN2R	1	UL 1007-AWG 20-RED	-	9	CH1P	1
9	LD-CN2R	2	UL 1007-AWG 20-BLK	-	9	CH1P	2

1	Added wires from page 8	stth	2025-08-26
Rev	Description	App	Date



HERU 70T / K  
Circuit diagram - Report list  
Wire Run List

ART. NUMBER 4040230	DRAWING NUMBER C-0016545	
STATUS	APPR BY STTH	DRAWN BY FROS
DATE 26.08.2025	REV 1	SHEET 10 / 10